

# A New MPPT Scheme Based on Komodo Mlipir Algorithm for Stand-Alone Solar PV System

Fathurrahman<sup>1</sup>, Khairun Saddami<sup>2</sup>, Rika Sri Utami<sup>3</sup>, Malahayati<sup>4</sup> Akhyar<sup>5</sup>

<sup>1,2,3</sup> Universitas Syiah Kuala, Darussalam, Banda Aceh, Aceh, 23111, Indonesia.

<sup>1</sup>Electrical Engineering Department, King Fahd University of Petroleum and Minerals, Saudi Arabia

<sup>4</sup>Universitas Islam Negeri Ar-Raniry, Darussalam, Banda Aceh, 23111, Indonesia

<sup>5</sup>Universiti Kebangsaan Malaysia, Bangi, Selangor, 43600, Malaysia.

## ARTICLE INFO

### Article history:

Received : 13/03/2025

Revised : 14/05/2025

Accepted : 30/10/2025

### Keywords:

PV Module, Maximum Power Point Tracking, Komodo Mlipir Algorithm

## ABSTRACT

The efficiency of PV modules remains relatively low, ranging from 15% to 35%, depending on the type of silicon technology used, including crystalline, polycrystalline, and thin-film. Then, the energy extraction efficiency from Solar Power Generation could be a lot higher (below 70%), especially in Solar Power Generation systems that still need to implement the Maximum Power Point Tracking (MPPT) algorithm. The MPPT algorithm is implemented in power electronic devices, such as boost converters, to optimise the power output of solar modules under various operating conditions, particularly during partial shading conditions. Various MPPT algorithms have been developed, each with its strengths and weaknesses. To enhance the efficiency of Solar Power Generation, this research will use a more effective state-of-the-art algorithm, namely the "Komodo Mlipir Algorithm" (KMA). KMA exhibits low system exploitation characteristics, utilising high exploration strategies, which align with the hunting behaviour of the Komodo dragon. This algorithm is expected to increase Solar Power Generation efficiency to above 90%.



This work is licensed under a [Creative Commons Attribution 4.0 International License](https://creativecommons.org/licenses/by/4.0/)

## Corresponding Author:

Fathurrahman

Universitas Syiah Kuala, Darussalam, Banda Aceh, Aceh, 23111, Indonesia.

Email : fathurrahman@usk.ac.id.

## 1. INTRODUCTION

The role of electricity remains the most effective and efficient method of mass-energy transfer directly utilised by humans, compared to other methods such as wind utilisation in sailboats and the use of petroleum for internal combustion engines. However, electrical energy is a secondary form derived from the manifestation of primary energy conversion processes, such as wind, water, geothermal heat, sunlight, petroleum, and nuclear processes. The World Bank reports that, as of January 2023, at least 91.3% of the global population had access to electricity [1].

Indonesia has a relatively high electrification ratio of 99.28%. However, it is regrettable that Indonesia still relies on 85.5% of its primary electricity sources on fossil energy. It is a highly polluting energy source and contributes significantly to environmental pollution. This situation presents a paradox, considering that Indonesia is located on the equator with an average solar irradiation of 4.8 kWh/m<sup>2</sup>/day, receiving 12 hours of sunlight per day [2-3]. Solar power generation is one primary energy source component with a relatively low percentage in Indonesia. In 2023, out of Indonesia's 8.64% renewable energy mix, PV contributed only 0.16% [4-5]. Based on Indonesia's Electricity Supply

Business Plan, the country aims for carbon neutrality by 2060, with an initial target of incorporating 23% new renewable energy into the energy mix by 2030.

One challenge in utilisation, however, is that the efficiency of PV modules is still relatively low, ranging from 15% to 35%, depending on the silicon technology used (crystalline, polycrystalline, or thin film). Furthermore, the energy extraction efficiency from Solar Power Generation could be higher, especially in PV systems that still require the implementation of the Maximum Power Point Tracking (MPPT) algorithm in the solar energy extraction process [6-7]. Many PV installations, especially rooftop (off-grid) PV sites, still need the implementation of the MPPT algorithm in their systems. Therefore, MPPT must be developed and disseminated to the public and the government. The primary contribution of this research is the development of an MPPT algorithm for PV systems, enabling the system to extract up to 95% of the solar energy converted by PV modules under various operating conditions.

## 2. RESEARCH METHOD

### 2.1. PV Modules and PV Systems

PV systems are power generation systems that comprise one or more solar modules connected in series or in parallel. PV systems typically includes power electronic devices that serve as interfaces between the PV modules and the load or battery. Based on the grid connection, PV systems can be categorised into two topologies: on-grid and off-grid systems [8]. PV cells are the primary components of PV modules, modelled as a diode connected to a resistor, as depicted in Figure 1. PV cells exhibit current and voltage characteristics expressed mathematically using Equation 1. [9-12]:

$$I = I_{ph} - I_d \left[ e^{\left( \frac{V+IR_s}{N_s kT/q} \right)} - 1 \right] - \left( \frac{V+I.R_s}{R_p} \right) \quad (1)$$

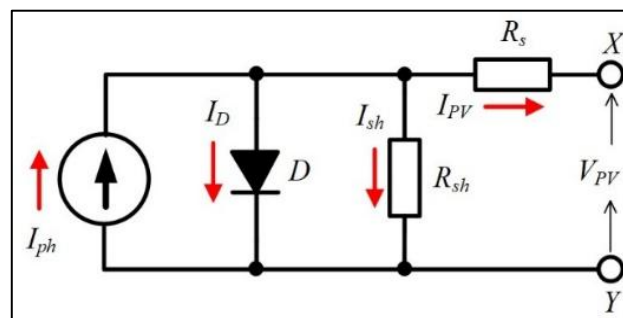

Figure 1. PV modules equivalent circuit

### 2.2. Maximum Power Point Tracking (MPPT)

MPPT (Maximum Power Point Tracking) is the automatic load regulation in a PV system to track the maximum power point under various module operating conditions, allowing the system to extract optimal output power [13]. The MPPT circuit comprises control and DC-DC converter circuits, which can be implemented as a buck, boost, CUK, SEPIC, or buck-boost converter [14]. The DC-DC converter is driven by the controller, which utilises the MPPT algorithm to adjust parameters, thereby enabling the transfer of maximum power from the PV source under various environmental and load conditions. In simple terms, the MPPT system is shown in Figure 2.

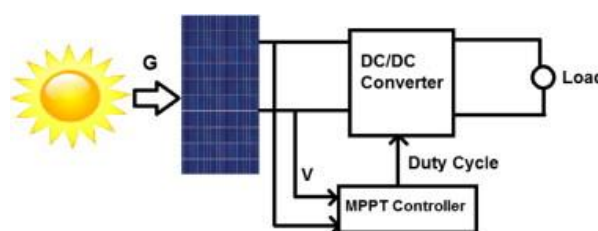

Figure 2. PV systems MPPT block diagram

### 2.3. MPPT Using KMA

MPPT (Maximum Power Point Tracking) is the automatic load regulation in a PV system to track the maximum power point under various module operating conditions, allowing the system to extract optimal output power [13]. The MPPT circuit comprises control and DC-DC converter circuits, which can be configured as buck, boost, CUK, SEPIC, or buck-boost converters [14]. The DC-DC converter is driven by the controller, which utilises the MPPT algorithm to adjust parameters, thereby enabling maximum power transfer from the PV source under various environmental and load conditions. In simple terms, the MPPT system is depicted in Figure 3.

MPPT (Maximum Power Point Tracking) is the automatic load regulation in a PV system to track the maximum power point under various module operating conditions, allowing the system to extract optimal output power [13]. The MPPT circuit comprises control and DC-DC converter circuits, which can be configured as buck, boost, CUK, SEPIC, or buck-boost converters [14]. The DC-DC converter is driven by the controller, which utilises the MPPT algorithm to adjust parameters, thereby enabling maximum power transfer from the PV source under various environmental and load conditions. In simple terms, the MPPT system is depicted in Figure 3 [15-16].

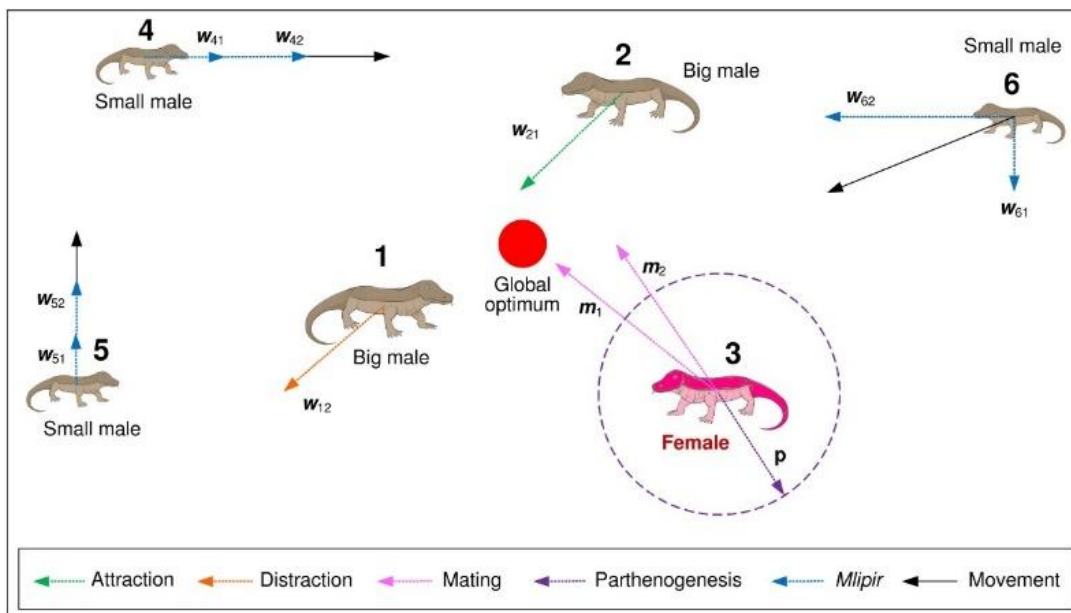

Figure 3. The representation of the KMA algorithm in searching for the optimal point

The utilisation of the KMA algorithm in the MPPT problem involves how the KMA algorithm attempts to reach the highest peak point of the P-V curve generated by MPPT, as illustrated in Figure 4.

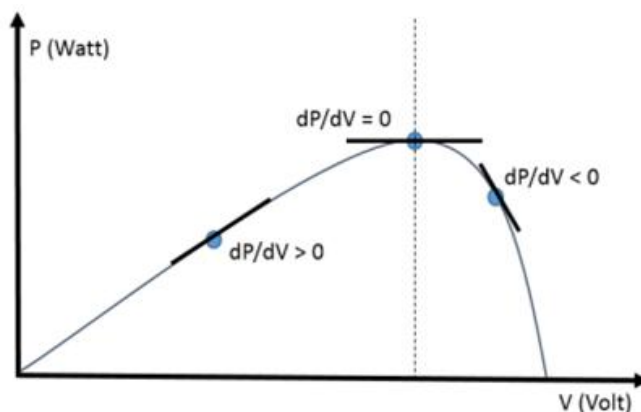
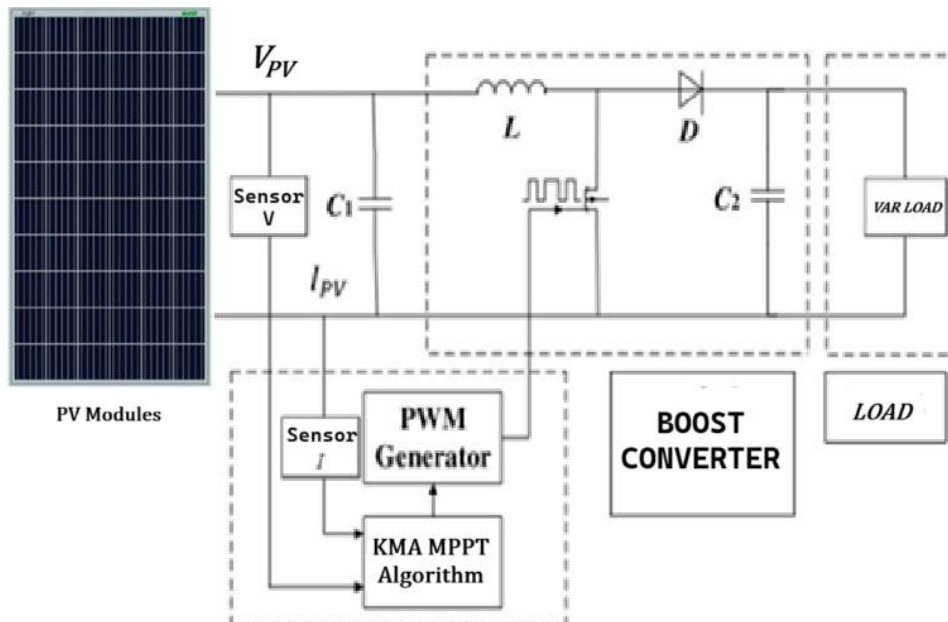

Figure 4. MPPT P\_V curve

## 2.4. Research Design

This research begins with a literature review from various sources. It is a quantitative study based on laboratory experiments. In this study, a prototype power electronic device in the form of a boost converter is constructed and controlled using the Komodo Mlipir Algorithm (KMA)[15-16]. The following steps involve data collection and the selection of parameter values for each component of the PV system and load, which are then simulated using computer programs such as PSIM or MATLAB. Subsequently, the controller for the boost converter power electronic device is designed, considering the calculated component values based on the technical data of the solar panels and the load. The constructed model is simulated, and power values are chosen as the main observed variables. After a successful simulation, the final steps involve building and testing the prototype. The entire research draws conclusions based on the results obtained from simulation and hardware testing.

The design, assembly, and measurement of the MPPT KMA experimental circuit were carried out in the Power Electronics Laboratory of the Electrical Engineering Department at USK. The data collection and analysis stages involve obtaining data by testing the equipment in the field. Once the data is obtained, it is analysed to determine whether the prototype can function appropriately according to the intended goals by examining the power output characteristics produced by the solar panel with and without MPPT.



**Figure 5.** Block diagram of the MPPT KMA system design

The partial shading condition is based on research done in [17], where three stages of solar irradiance are simulated. The first shading configuration is set up so that two modules (partially shaded) receive solar irradiance at  $0.6 \text{ kW/m}^2$ , while the remaining two receive  $1 \text{ kW/m}^2$  of solar irradiance. This configuration is Partial Shading Conditions (PSC) Pattern 1. The second configuration is set to a Uniform Insolation Condition (UIC), where all modules receive  $1 \text{ kW/m}^2$  of solar irradiation (under no shading condition). The third shading configuration is set up where one modules (partially shaded) receive the solar irradiance at  $0.7 \text{ kW/m}^2$ , two modules (partially shaded) receive the solar irradiance at  $0.9 \text{ kW/m}^2$ , and the last module receives  $1 \text{ kW/m}^2$ . This configuration is Partial Shading Conditions (PSC) Pattern 2. Every shading condition stage is simulated for 4 seconds. Figure 6 illustrates the PV three-shading condition scenario.

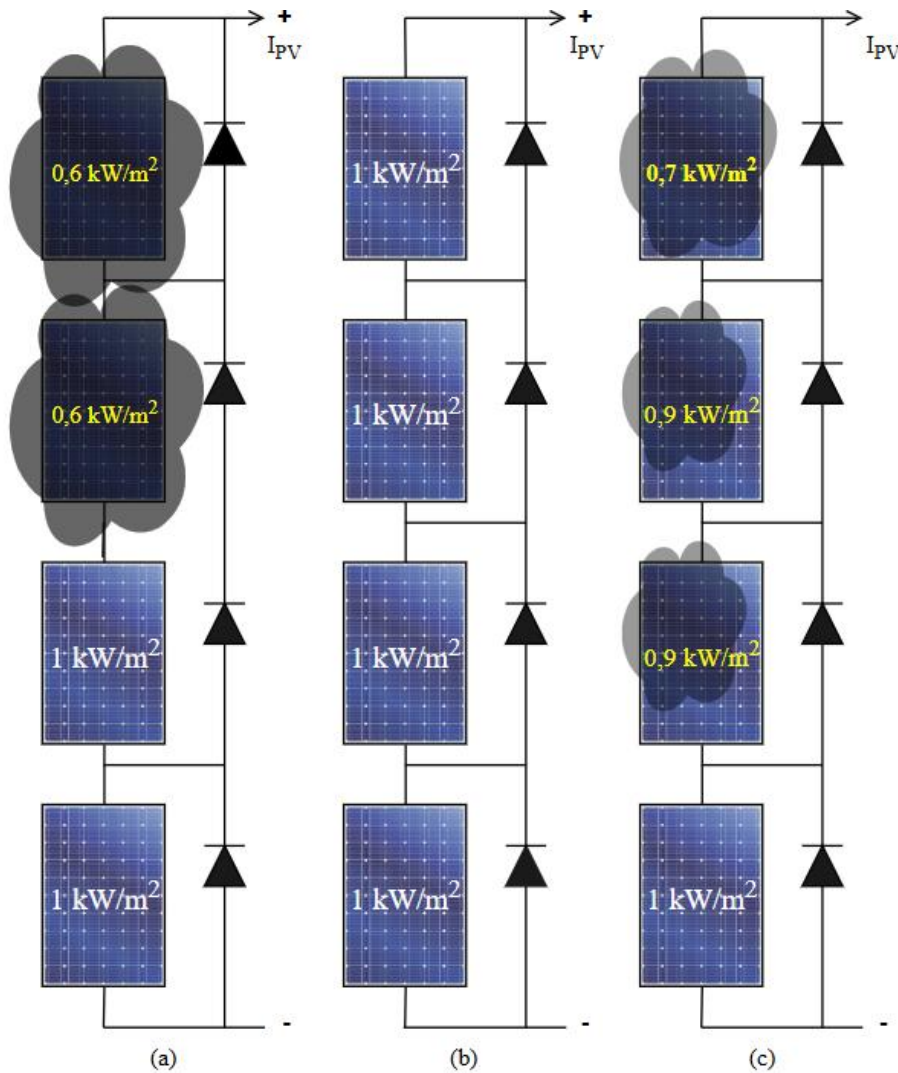

**Figure 6.** Scenario of PV Arrays Shading Condition (a) PSC Pattern 1; (b) UIC; (c) PSC Pattern 2

In this data analysis, efficiency will also be considered, both when using a conventional method and when using an MPPT. The prototype is functioning correctly if the obtained data aligns with the data in Table 1.

**Table 1.** Shading condition scenario

No.	Shading Condition	Efficiency
1.	Partial Shading Condition Schema 1	> 90 %
2.	No partial Shading Condition	> 90 %
3.	Partial Shading Condition Schema 1	> 90 %

### 3. RESULTS AND DISCUSSION

The Experimental setup is shown in Figure 7. The PV system and load are then simulated using MATLAB. The simulation uses 4 x 100 Wp or 400 Wp PV Modules with a variable load. The change in solar irradiance occurs every 4 seconds. Based on the shading scenarios developed in Figure 6, the maximum possible power that can be extracted from the PV arrays is calculated and plotted as the set point value. The computed maximum power value is shown in Figure 7 and Table 2.

**Table 2.** Maximum power output from every shading scenario

No.	Shading Condition	Max Output Power (W)
1.	PSC Pattern 1	640
2.	No partial Shading Condition (UIC)	1000
3.	PSC Pattern 1	760

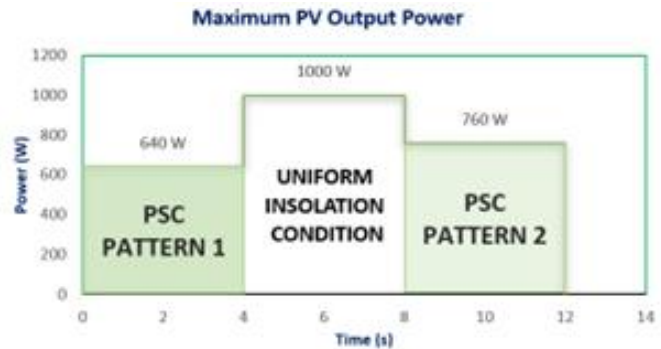

**Figure 7.** Maximum output PV array power for every given shading scenario

The simulation of the proposed MPPT Algorithm is computed using MATLAB/SIMULINK software. The MATLAB simulation set-up (block diagrams) is shown in Figure 6. The KMA Algorithm is employed in the Boost converter by controlling the MOSFET PWM drive, where the MOSFET operates based on the algorithm to vary the voltage accordingly, thereby producing a power value as close as possible to the set point value, as specified in Table 2 and Figure 7.

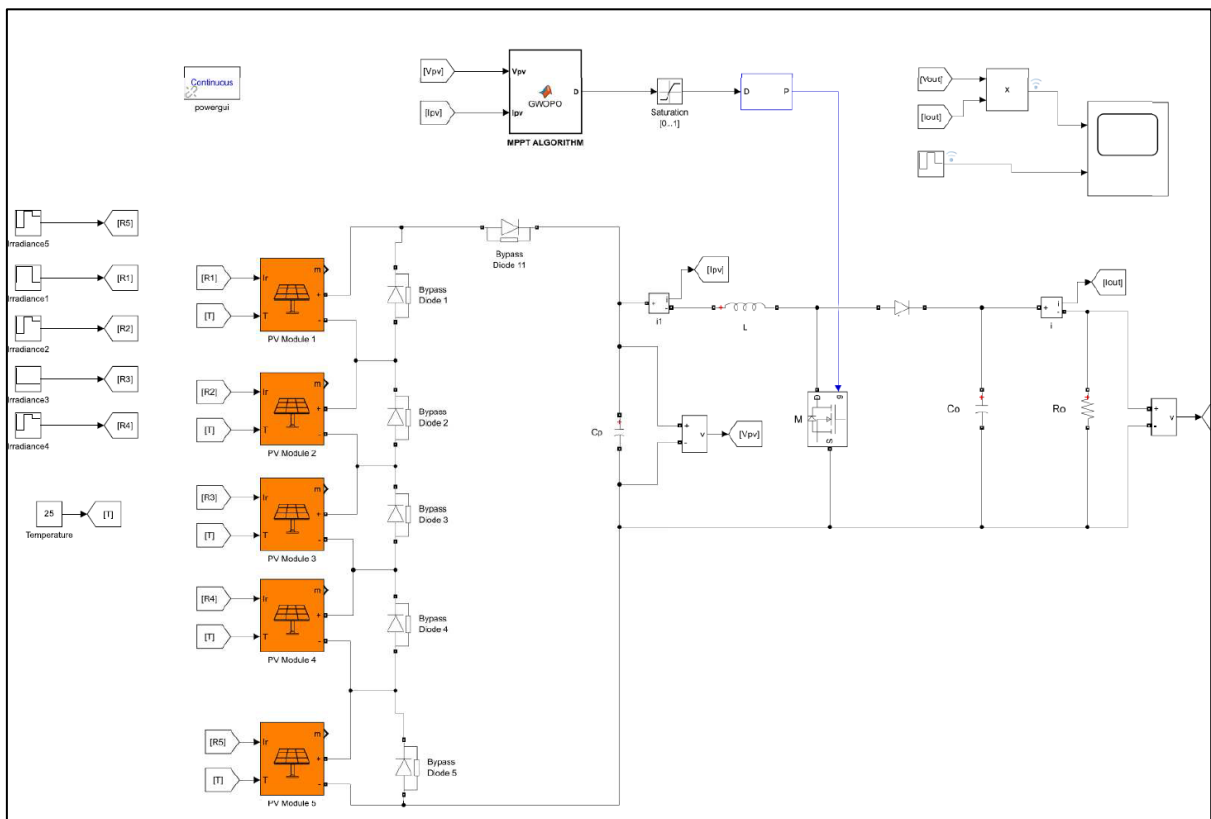

**Figure 6.** Simulation diagram setup

The power and output voltage of the solar module, as determined by the KMA MPPT algorithm, are shown in Figure 10. The green line represents the maximum power output from the solar module based on solar irradiance, and the yellow line represents the actual power produced by the solar module.

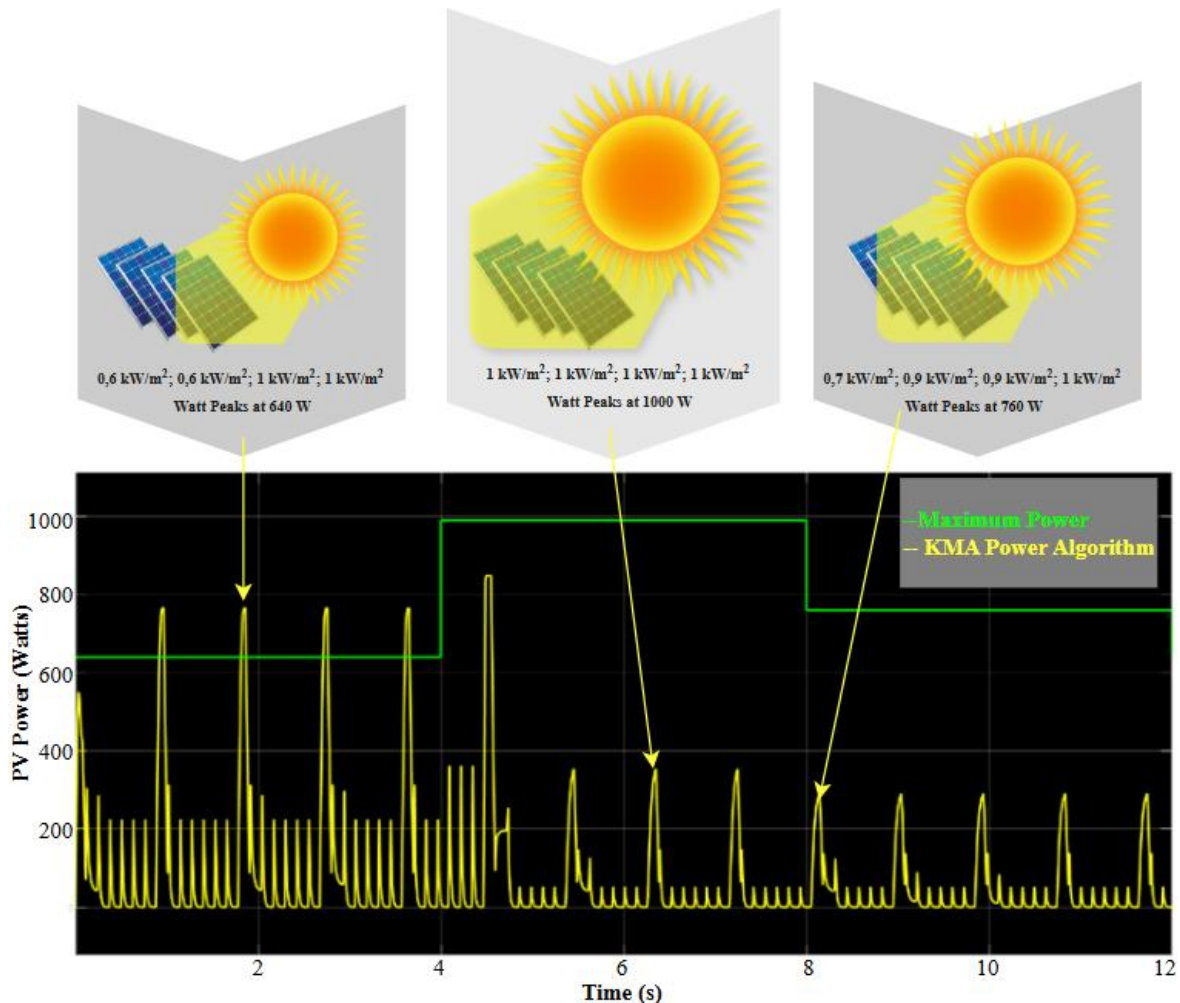

**Figure 7.** Maximum power based on Solar Irradiance versus true PV Array Power Output using KMA

The performance of the solar module, specifically its output power and voltage as regulated by the KMA (Komodo Movement Algorithm) Maximum Power Point Tracking (MPPT) strategy, is illustrated in Figure 10. In the figure, the green line signifies the theoretical maximum power that the solar module is capable of generating under given solar irradiance conditions. This represents the ideal or reference power output. In contrast, the yellow line indicates the actual power generated by the solar module when operated using the current implementation of the KMA algorithm.

As shown in the figure, the KMA algorithm strives to track the maximum power point (MPP) under varying irradiance conditions. While it demonstrates a general tendency to track the MPP trajectory, a noticeable deviation remains between the ideal and actual power output curves. Specifically, the system efficiency remains below 90%, indicating a suboptimal energy harvesting performance at this simulation stage.

This reduced efficiency is attributed to the fact that the current KMA algorithm is still in its initial development phase, referred to as Stage One of the simulation. At this stage, only a portion of the entire algorithm has been implemented, and not all the behavioural dynamics of the Komodo-inspired search strategy have been integrated. The complete KMA algorithm comprises three distinct stages, each modelled after the characteristic movements of different members of a Komodo dragon group: large males, females, and petite males, as illustrated in Figure 3. Stage One corresponds to the basic search behaviour inspired by the movement of large male Komodo dragons, which typically involves broader, exploratory searching with less precision. As the simulation progresses into Stage Two and Stage Three, incorporating the more refined and convergent movements of females and petite males, the algorithm is expected to achieve significantly better convergence towards the actual maximum power point. This

progression is expected to enhance tracking accuracy and increase the overall efficiency of the MPPT process.

Therefore, while the current results are promising in showcasing the initial tracking capabilities of the KMA algorithm, further improvements are expected once all behavioural stages are integrated. The full implementation of the algorithm is likely to yield a more precise and responsive MPPT strategy, thereby reducing power losses and enhancing the reliability of solar energy conversion under dynamic environmental conditions.

#### 4. CONCLUSION

In conclusion, the preliminary simulation results demonstrate that the KMA (Komodo Movement Algorithm) exhibits a fundamental ability to track the maximum power point (MPP) of the photovoltaic (PV) system under varying irradiance conditions. Despite this, the observed tracking efficiency currently remains below 90%. This limitation is primarily due to the algorithm being in its early stage of development, specifically Stage One of the three-stage simulation framework. At this initial stage, only movement patterns inspired by adult male Komodo dragons have been implemented, focusing on broad and exploratory search behaviour.

The full potential of the KMA algorithm is expected to emerge as the subsequent stages are incorporated. Stages Two and Three will simulate the more adaptive and convergent behaviours inspired by female and juvenile Komodo dragons, respectively. These stages are designed to refine the search process, enhance local exploitation, and improve the overall convergence towards the global maximum power point. Once all three behavioural stages are fully integrated, the algorithm is anticipated to significantly enhance its MPPT accuracy and operational efficiency, ultimately ensuring more effective energy harvesting from the solar module across a broader range of environmental conditions.

Future work will focus on implementing and validating these additional stages, as well as benchmarking the complete KMA algorithm against other established MPPT techniques to quantify its advantages in real-world scenarios.

#### Acknowledgments

Thanks to the Institute for Research and Community Service of Universitas Syiah Kuala (LPPM USK), the research is funded by LPPM USK under the Research Grant Scheme Penelitian Asisten Ahli, Grant No. 382/UN11.2.1/PT.01.03/PNBP/2023.

#### REFERENCES

- [1] World Bank Group, World Development Indicators, (2022) "Access to electricity (% of population)", [Online]. Available: <https://data.worldbank.org/indicator/EG.ELC.ACCS.ZS?end=2022&start=2019>.
- [2] N. Winanti, A. Purwadi, B. Halimi and N. Heryana, "Study and Design of Energy-Saving Solar Lamp for Small Island in Indonesia: Matakus Island," (2018) Conference on Power Engineering and Renewable Energy (ICPERE), Solo, Indonesia, 2018, pp. 1-5, doi: 10.1109/ICPERE.2018.8739672.
- [3] T. Tarmizi, S. Syahrial and F. Fathurrahman, "Design of PV System with DC distribution for Rural Electricity," *2021 International Conference on Computer System, Information Technology, and Electrical Engineering (COSITE)*, Banda Aceh, Indonesia, (2021), pp. 46-50, doi: 10.1109/COSITE52651.2021.9649537.
- [4] *Handbook of Energy & Economic Statistics of Indonesia 2023*, The Ministry of Energy and Mineral Resources, Jakarta, Indonesia, 2023. Accessed: February 25, (2025) [Online]. Available: <https://esdm.go.id/assets/media/content/content-handbook-of-energy-and-economic-statistics-of-indonesia-2023.pdf>.

- [5] *Indonesia Energy Transition Outlook 2024: Peaking Indonesia's Energy Sector Emission by 2030: The Beginning or The End of Energy Transition Promise*, Institute for Essential Services Reform, Jakarta, Indonesia (2023). Accessed: March 05, 2025 [Online]. Available: <https://iesr.or.id/wp-content/uploads/2024/03/Indonesia-Energy-Transition-Outlook-2024-1.pdf>
- [6] N. S. Lubis, "Efisiensi Daya Keluaran Generator Photovoltaic (GPV) Menggunakan Maximum Power Point Tracking (MPPT) Dengan Algoritma Perturb and Observe (P&O) dan MPPT Standard Reference," B.S Thesis, Dept. of Physics, Universitas Sumatera Utara, Medan, Indonesia, 2019.
- [7] M. Effendy, N. A. Mardiyah, K. Hidayat, (2017) "Implementasi Maximum Power Point Tracking pada Photovoltaic Berbasis P&O-Fuzzy," *Jurnal Nasional Teknik Elektro dan Teknologi Informatika*, vol. 6, no. 1, pp. 2–7, 2017.
- [8] *Guidelines for the Feasibility Study of a Solar Power Plant (PLTS)*," Ditjen EBTKE - KESDM in collaboration with USAID Indonesia Clean Energy Development II, Jakarta, Indonesia, pp. 30-31, 2018.
- [9] T. Le, H. Colin, F. A. Shakarchi and T. T. Quoc, (2018) "Improved Matlab Simulink Two-diode Model of PV Module and Method of Fast Large-Scale PV System Simulation," 7th International Conference on Renewable Energy Research and Applications (ICRERA), pp. 982-985, doi: 10.1109/ICRERA.2018.8566792.
- [10] K. Basaran, N. Sabit, and S. Borekci, (2016) "Energy management for on-grid and off-grid wind/PV and battery hybrid systems," *Journal of IET Renewable Power Generation* vol. 148, pp. 148–162.
- [11] M. N. Dehedkar and S. Vitthalrao Murkute, (2018) "Optimization of PV System using Distributed MPPT Control," *2018 International Conference on System Modeling & Advancement in Research Trends (SMART)*, pp. 216-220, doi: 10.1109/SYSMART.2018.8746931.
- [12] Chouder, S. Silvestre, B. Taghezouit, E. Karatepe, (2013) "Monitoring, modelling and simulation of PV systems using LabVIEW," *Solar Energy*, Volume 91, pp 337-349, ISSN 0038-092X.
- [13] Attou, A. Massoum, and M. Saidi, (2014) "Photovoltaic Power Control Using 40 MPPT and Boost Converter," *Balk. J. Electr. Comput. Eng.*, vol. 2, no. 1, pp. 23–27.
- [14] N. Nguyen, V. T. Nguyen, M. Q. Duong, K. H. Le, H. H. Nguyen, and A. T. Doan, (2020) "Propose a MPPT Algorithm Based on Thevenin Equivalent Circuit for Improving Photovoltaic System Operation," *Front. Energy Res.*, vol. 8.
- [15] Suyanto, S., Ariyanto, A. A., & Ariyanto, A. F. (2022). Komodo Mlipir Algorithm. *Applied Soft Computing*, vol. 114, pp. 10804.
- [16] Q. Liu, & X. Zhang, (2022). Improved Adaptive Komodo Mlipir Algorithm. *IEEE Access*, vol. 10, pp. 67883-67897.
- [17] Muyassar, M. et al. 2022. A GWO-P&O Algorithm MPPT for PV Systems Under UIC and PSC. *Jurnal Nasional Teknik Elektro*. 11, 3 (Nov. 2022).